

Industrial Gas Springs Ltd

22 Wates Way, Mitcham, Surrey CR4 4HR
Tel: 020 8646 6595 - Fax: 020 8646 6594
Email: sales@igsltd.co.uk
www.industrialgassprings.com



Industrial Gas Springs

Locking gas springs actuators

Release head dimensions

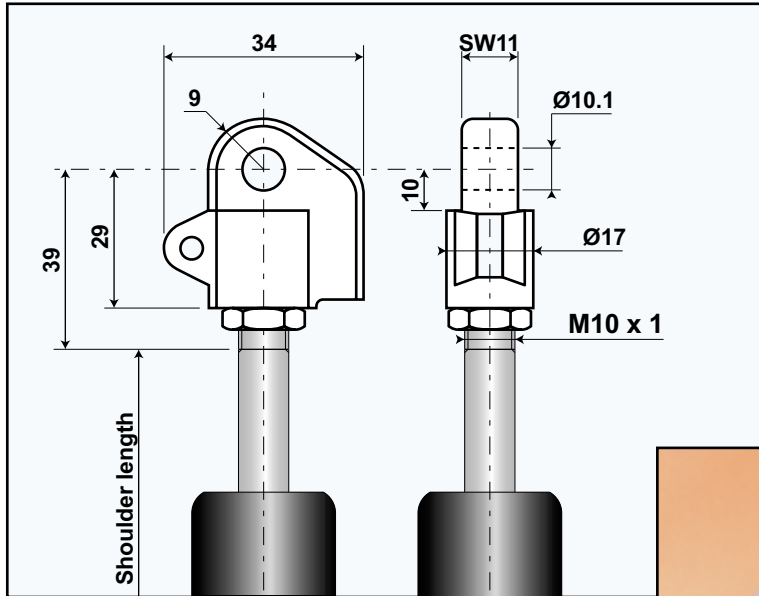

Cable release kit

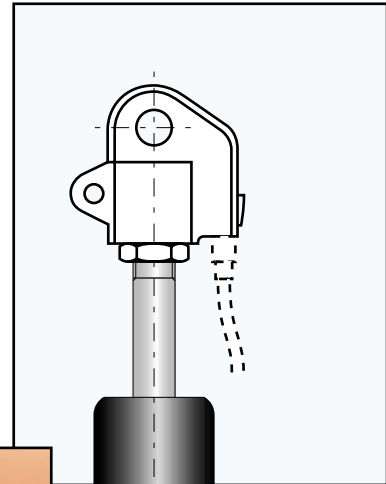

Code: F10-LS-KIT 1

Supplied pre-assembled with:
Release head
Cable Lever + Pin
(cable not supplied)

Release eye assembly - Type A

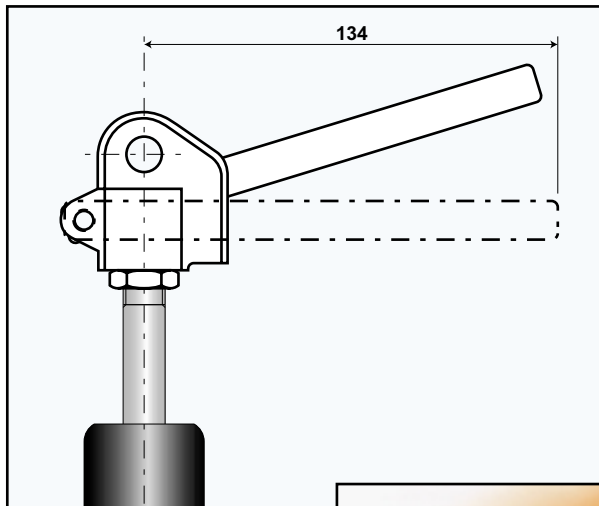

Code: F10-LS-KIT 2

Supplied as a kit:
Release head
Lever A + Pin

Release eye assembly - Type B

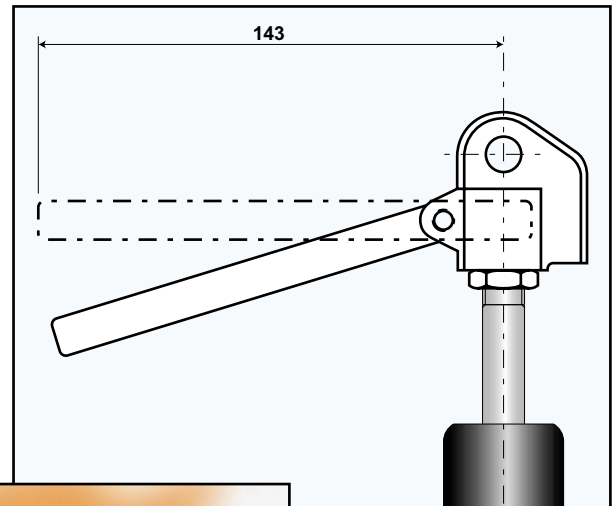

Code: F10-LS-KIT 3

Supplied as a kit:
Release head
Lever B + Pin

