

150mm stroke gate gas spring - Kit

Page 1 of 3

Gas spring order codes:

With a force of 100 Newtons: **F100113/BB/0100**

With a force of 300 Newtons: **F100113/BB/0300**

With a force of 500 Newtons: **F100113/BB/0500**

Price breaks.

Unit price depends on the quantity of gas springs ordered:

Quantity ordered	1 to 4	5 to 14	15 to 49	50 to 99
Gas spring unit price	£92.25	£66.49	£41.00	£35.73
Packing & Carriage cost	£16.90	£16.90	£20.60	£25.90

Supplied with:

→ 1 x gas spring reference: 8/23-150-470(506)-SME-SME-BV100N-FD (fitted with 2-off Eyes)

→ 2 x nylon ball joints

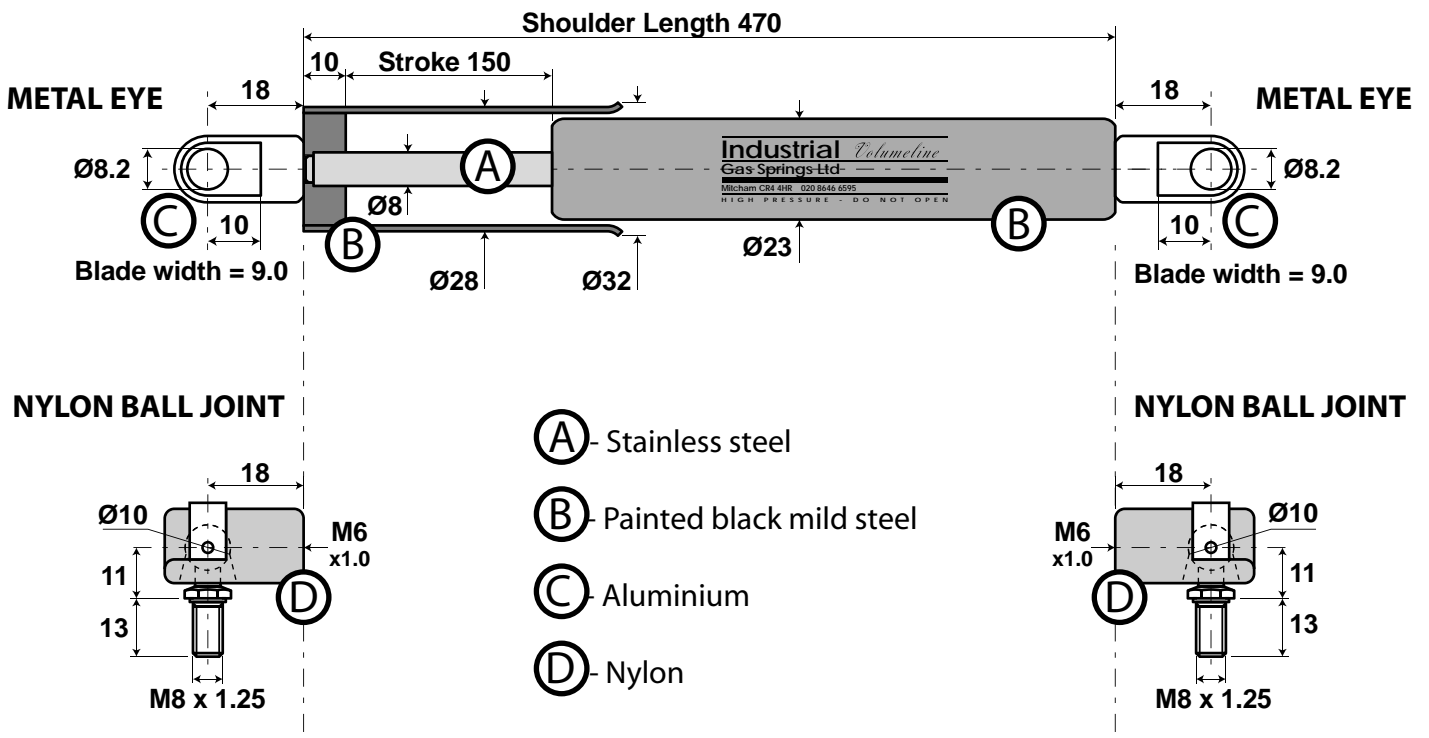

FEATURES

- Slow and safe closing motion of gates
- From 100 up to 550 Newton (56kg)
- Progression factor $k = 1.3$
- Includes a force release valve
- Free in compression
- Fully damped in extension

- Stainless steel rod
- Protective metal shroud
- Black painted resistant steel body and shroud
- Operating temperature: -25°C to $+70^{\circ}\text{C}$
- Supplied as a kit with 2 nylon ball joints with studs and 2 metal eyes. If required, brackets and extra end-fittings must be ordered separately.

Gate gas spring - Accessories

Optional extras

Type C Bracket
Zinc plated steel
Code: FC-8

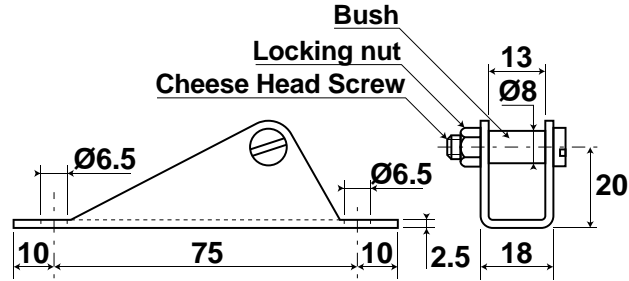

Type B2 Bracket
Zinc plated steel
Code: FB2-8

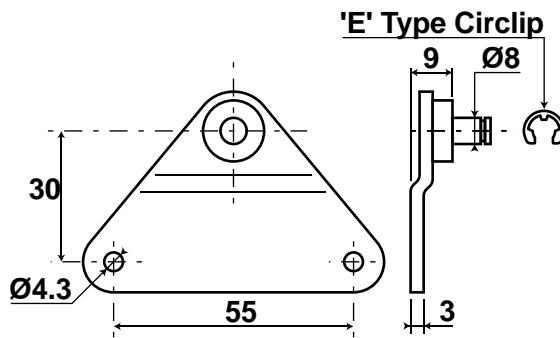

Type A2 Bracket
Zinc plated steel
Code: FA2-10

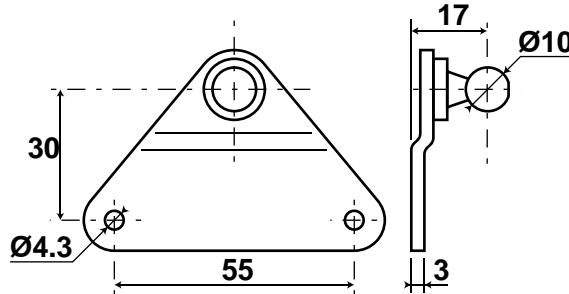

Ball joint
Zinc plated steel
Code: F06-MB-D10

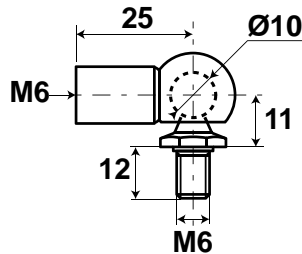

Ball joint
Stainless steel 304
Code: F06-XMB-D10

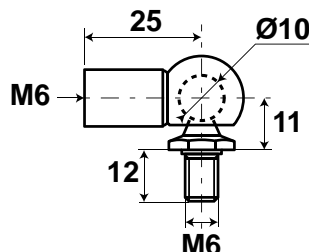

150mm stroke gate gas spring - Installation

Typical position of the gas spring and end-fittings on a gate:

Page 3 of 3

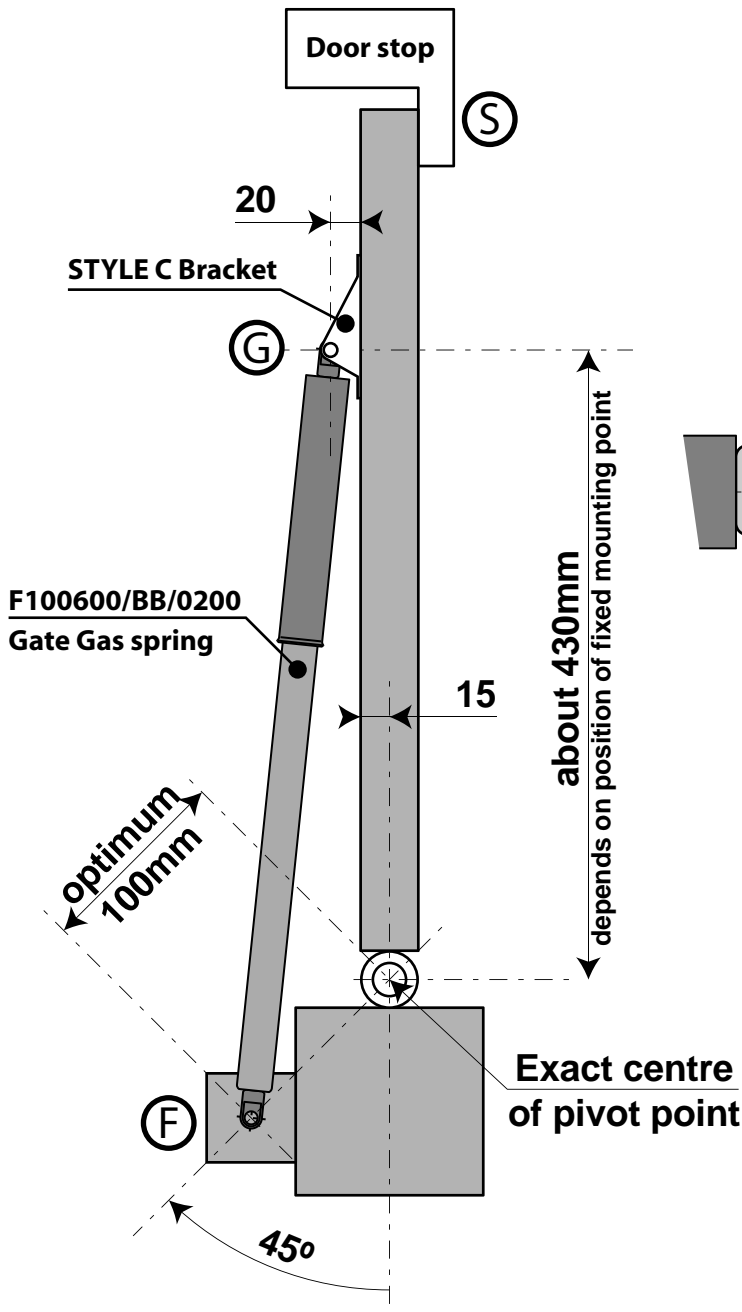

Possible mounting solutions

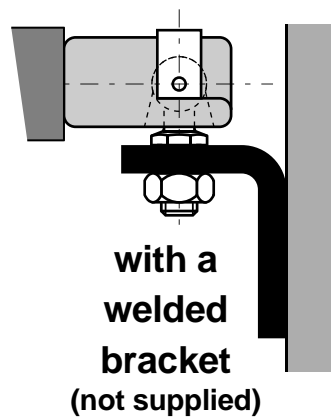

Using a FC-8 bracket

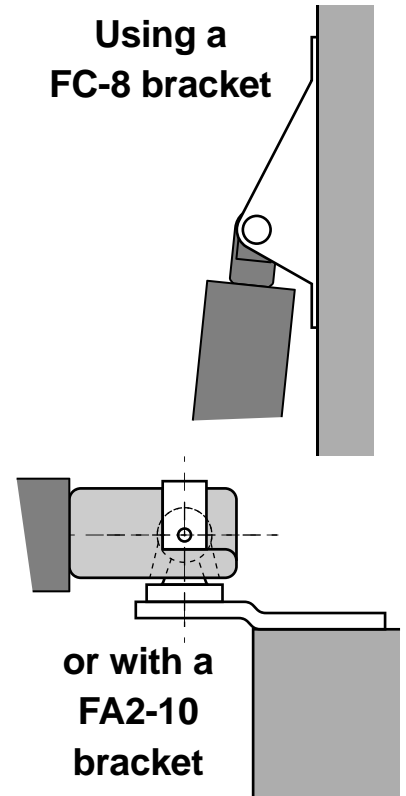

Installation

- First fit a bracket/fixing at point (F) in such way that the centre of the mounting point is between 80 and 100mm away from the centre of the pivot point (maximum value is also the best: 100mm), about 45° behind as shown on the above drawing.
- Once bracket (F) is secured, fit bracket (G) in such way that the gas spring will be compressed 2 to 5mm when the gate is closed against the door stop.
- When using metal eyes, ensure that both brackets are on the same line and that the gas spring is never exposed to lateral forces.
- Make sure that the gate's hinge is regularly greased so the friction does not increase dramatically overtime.

This solution will only work when the gas spring can be fitted as per the above drawing, or in a very similar position.

If the gate is not fully free to rotate (friction in the hinge), then you will need to order a slightly stronger gas spring charged at up to 550 N.